

PROJECT	QUANTITY	ITEM NO
---------	----------	---------

# High Volume Open Fryers

**OFE 291** Electric



OFE 291 high volume electric open fryer

Henny Penny high volume open fryers offer tremendous throughput in a highly reliable frying platform with programmable operation, oil functions and fast, easy filtration.

The Henny Penny OFE 291 is the only single well electric open fryer available that can cook up to 21 lb (9.5 kg) of food per load. For higher volume operations, that can mean significant savings in time, labor, frying oil, energy and maintenance compared to an equivalent capacity of smaller fryers from other manufacturers.

Henny Penny high volume electric open fryers combine power with high-efficiency immersed elements to recover temperature very quickly. Fast recovery translates into higher throughput, lower energy costs and longer frying oil life. Large loads are cooked evenly and handled easily

with the patented counter-balance lift system.

Henny Penny open fryers have a built-in filtration system that filters and returns hot frying oil in minutes. No separate pumps and pans, no handling hot oil. Frequent filtering extends frying oil life, improves product quality and reduces oil costs.

The Computron™ 8000 control features automatic, programmable operation, as well as energy-saving, filtration and cook management functions.

## Standard Features

- Heavy-duty stainless steel vat with 7-year warranty
- Fry vat is fully insulated for energy efficient operation
- High-efficiency heating elements generate fast recovery and energy savings
- Cold zone below heating elements helps extend oil life
- High-limit temperature protection
- Patented counter-balanced basket lift for easy loading and unloading
- Built-in filtration system
- Raised edge on deck reduces spills
- Smaller footprint saves floor space and cookline frontage
- Stainless steel construction for easy-cleaning and long life
- 4 heavy-duty casters, 2 locking
- Computron™ 8000 control
  - 10 programmable cook cycles
  - Melt mode
  - Idle mode
  - Clean-out mode
  - Water detection alert
  - Load compensation
  - Proportional control
  - Optional filter prompt and customizable filter tracking
  - 16-character digital display with multiple language settings

## Accessories shipped with unit

- Loading carrier
- Basket configuration, choose one:
  - Full basket—4 flat wire baskets, 1 wire rack cover, rack handle
  - Half-size rack—4 wire racks, 1 wire rack cover, rack handle
- Stirrer and drain clean-out rod
- Filter screen and 2 PHT filter envelopes

## Accessories and options available separately

- Direct Connect shortening disposal
- Fryer Shortening Shuttle®
- Filter rinse hose
- Filter pan dolly

<input type="checkbox"/> APPROVED	<input type="checkbox"/> APPROVED AS NOTED	<input type="checkbox"/> RESUBMIT
AUTHORIZED SIGNATURE		DATE

**HENNY PENNY**  
Engineered to Last

# High Volume Open Fryers

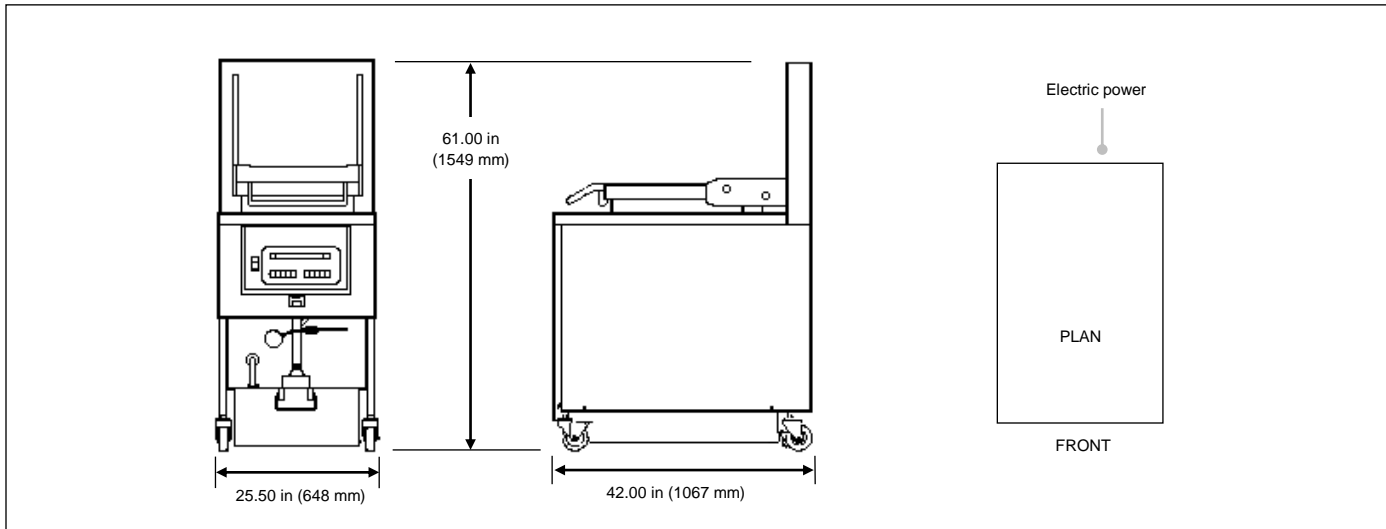
**OFE 291** Electric

**Dimensions**

Height	61.00 in	(1549 mm)
Width	25.50 in	(648 mm)
Depth	42.00 in	(1067 mm)

**Crated**

Length	46 in	(1168 mm)
Depth	30 in	(762 mm)
Height	70 in	(1778 mm)
Volume	56 ft <sup>3</sup>	(1.6 m <sup>3</sup> )
Weight	593 lb	(269 kg)

**Required clearances**

Sides	6 in	(152 mm)	air flow
Back	6 in	(152 mm)	air flow
Front	38 in	(965 mm)	remove filter pan

**Electrical**

Volts	Phase	Hertz	kW	Amps	Wire*
208	3	60	17.0	47.2	3+G
240	3	60	17.0	40.9	3+G
380-415	3	50	17.0	24.6	3NG
400	3	50	17.0	24.6	3NG
480	3	60	17.0	20.5	3+G

**Heating**

4 immersed elements  
4.25 kW each/17.0 kW total

**Capacity**

Product	21 lb (9.5 kg)
Oil	100 lb or 45 L

**Bidding specifications**

Provide Henny Penny model OFE 291 high-volume electric open fryer, 21 lb (9.5 kg) capacity per load, with built-in filtration system.

Unit shall incorporate:

- Computron™ 8000 control system with programmable or manual operation, LED digital display, idle and melt modes, load compensation, filtration tracking and 7-day history
- Fry vat of heavy duty stainless steel with 7-year warranty
- Patented counter-balanced basket lift system for easy handling of large loads
- 4 heavy-duty casters, 2 locking
- Starter kit with choice of filtering media

**Laboratory certifications**

\*Power cord and plug must be installed on site by a qualified electrician.

Continuing product improvement may subject specifications to change without notice.

**24 Hour Technical Support:**  
Henny Penny Technical Service  
800 417.8405  
[technicalservices@hennypenny.com](mailto:technicalservices@hennypenny.com)

**Henny Penny Corporation**  
PO Box 60 Eaton OH 45320 USA  
+1 937 456.8400 800 417.8417  
+1 937 456.8434 Fax 800 417.8434 Fax  
[www.hennypenny.com](http://www.hennypenny.com)

**HENNY PENNY**  
Engineered to Last